

# DUST MONKEY BLIND

WWW.DUSTMONKEY.NET

## SPECIFICATIONS

The BLIND modular extraction rail is suitable primarily for aspiration of car exhaust, welding fumes, or fumes of any other kind. The extraction rail has been met with a great success in truck repairing workshops where contamination of the workplace was prevented by the highly mobile flexible hose of the BLIND mobile extraction rail. Installation of an arm on the sliding rail enables the extraction of fumes produced during welding operations or the removal of dusty

air. The BLIND is made in robust aluminum sections, and the extraction rail has a variable cross-section depending on the desired air flow rate (BLIND 190 and BLIND 240). The slit on the bottom allows longitudinal movement of the extracting point. The vacuum produced by the exhauster is constant thanks to the presence of two rubber lips fixed in proximity of the slit and thus making the extraction system airtight. The sliding element runs on nylon wheels along a robust rail system inside the



extraction channel. The BLIND extraction rail is supplied in standard lengths of 7, 10, 13, and 20 feet, flanged on both sides, which can then be assembled to reach the desired length (which allows the system to be expanded later). Several extracting sliding elements can be easily inserted into the modular rail.

### FEATURES

- \* The BLIND modular extraction rail is suitable primarily for aspiration of car exhaust, welding fumes, or fumes of any other kind.
- \* Modular design makes assembling and adding new pieces easy!
- \* Supplied in standard lengths of 7, 10, 13, and 20 feet, flanged on both sides.

### OPTIONS

- \* Piping (galvanized or stainless steel)
- \* Extra pieces available to build the rail to the lengths required
- \* Extraction arm for mounting on rail

## DIMENSIONS, ETC.

Dust Monkey products are manufactured in metric sizes but described here and on the web site in their closest English equivalent. Representative sizes and dimensions are described here. Custom sizes and materials are available.

Diameters:  
63 mm: 2.5 inches  
75 mm: 3 inches  
100 mm: 4 inches  
125 mm: 5 inches  
160 mm: 6 inches  
200 mm: 8 inches

Lengths:  
1.5m: 5 feet  
2.0m: 6 feet  
3.0m: 10 feet  
4.0m: 13 feet  
5.0m: 16 feet  
6.0m: 20 feet  
7.0m: 23 feet  
8.0m: 26 feet  
9.0m: 30 feet

WWW.DUSTMONKEY.NET

Komodo Enterprises, Inc. DBA  
Dust Monkey  
2620 S. Maryland Pkwy  
Suite 14, Box 863  
Las Vegas, NV 89109

California Office  
8915 Research Dr.  
Irvine CA, 92618

Tel: 949.341.0314  
Fax: 949.341.0315

E-mail: info@dustmonkey.net



*Tough, Durable,  
Rugged, Reliable,  
Stout Construction*

Visit all our web sites:  
WWW.DUSTMONKEY.NET  
WWW.DUCTMONKEY.NET  
WWW.MONKEYARMS.COM



*Experts in Dust, and  
Fume Control.*

WWW.DUSTMONKEY.NET

## MODELS AVAILABLE

BLIND	DIMENSIONS (IN)						CAR EXHAUST (CFM)
	A	B	C (FT)	D	E	EQ (Ø)	
190	2	9	10	9	5	8	1383
190	2	9	20	9	5	8	1383
240	2	9	7	9	8	10	2237
240	2	9	13	9	8	10	2237
240	2	9	20	9	8	10	2237

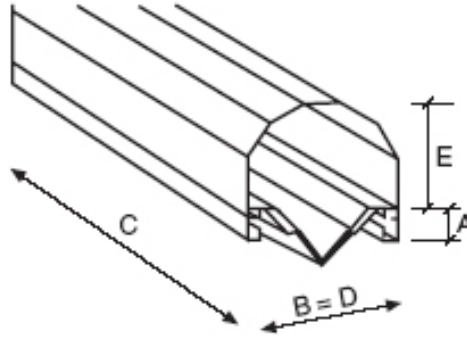

## TERMS AND CONDITIONS

### PAYMENTS AND TERMS

Prices quoted are good for 30 days unless otherwise noted. Dust Monkey accepts cash, check, wire transfer, or credit cards. All prices are quote in US Dollars, unless otherwise noted. All sales are final. All freight is FOB, Las Vegas, Nevada unless otherwise noted. All goods remain the property of Dust Monkey until paid in full. Payment is due at time of order unless credit has been granted. All past due accounts accrue a service fee of 3% per month. Dust Monkey is a DBA of Komodo Enterprises, Inc., a Nevada Corporation.

### PRIVACY STATEMENT

Komodo Enterprises Inc. respects your privacy and will not divulge your contact information to any third party organization or entity without your express permission. In addition, our web sites gather no unauthorized information from your computer during your visit with us. All phone calls to Dust Monkey may be monitored or recorded.

### ACCURACY

Dust Monkey assumes no responsibility for errors or omissions in this web site or documents which are referenced by or linked to this site. This site could include technical or other inaccuracies. Changes are periodically added to the information, and Dust Monkey may change the products or services described at any time. Contact Customer Service for further information before relying on any information contained herein. The information provided on this site, including text, images, and links, are provided "AS IS" by Dust Monkey solely as a convenience to its visitors. This information is without any warranties, express or implied, including but not limited to warranties of merchantability, fitness for a particular purpose or non-infringement.

### WARRANTY & INDEMNITY

Dust Monkey warrants products it manufactures for a period of 90 days to the original purchaser from the date of purchase. Items not manufactured by Dust Monkey are limited to their own manufacturer's warranties. This warranty does not apply to defects due directly or indirectly to misuse, negligence, accidents, abuse, repairs, or alterations or lack of maintenance. This is Dust Monkey's sole written warranty and any and all warranties that may be implied by law, including any merchantability or fitness, for any particular purpose, are hereby limited to the duration of this written warranty. Dust Monkey does not warrant or represent that the merchandise complies with the provisions of any law or acts. In no event shall Dust Monkey liability under this warranty exceed the purchase price paid for the product. Both parties agree to binding arbitration in Las Vegas, Nevada. Dust Monkey shall in no event be liable for death, injuries to persons or property or for incidental, and contingent, special, or consequential damages arising from the use of our products. Dust Monkey warrants products only for the specific use expressly agreed to at time of purchase by Dust Monkey in writing. Motors should only be started and stopped up to 4 - 10 times per hour. Starting motors more frequently can cause heat build up and can cause the motor overload to trip or cause motor damage. In general, motors should be started and stopped as little as possible for maximum lifespan and best economy (electrical use). \*Note: Motors should be protected from extreme weather to prolong motor life. All claims, including claims covered under the limited warranty, are subject to inspection and investigation before Buyer's claim is settled. Any parts returned for warranty or repair will not be accepted without an RMA number and must be shipped pre-paid. Contact Customer Service with the original bill of sale to obtain an RMA number.